

PISTON ACCUMULATOR

Installation and operation manual

Revision 2024-1



hydroll

THE PISTON ACCUMULATOR COMPANY



Content

1.0	INTRODUCTION	4
2.0	GENERAL SAFETY INSTRUCTIONS	5
3.0	WARRANTY	6
3.1	Limitation of the liability	6
4.0	TECHNICAL SPECIFICATIONS, LABELS AND STRUCTURE	7
4.1	Technical specifications and labels	7
4.2	General illustration of the accumulator structure	8
5.0	INSTALLATION	9
6.0	MAINTENANCE	11
6.1	Checking the pre-charge pressure	11
6.2	HPCk charging kit for gas valve M16	14
6.3	M28 charging kit for gas valve M28	16
7.0	CALCULATED LIFE TIME - DYNAMIC LOAD	18
8.0	STORAGE AND TRANSPORTATION	19
8.1	Storage	19
8.2	Transportation	20
9.0	PRACTICAL ADVICES FOR USER	21
10.0	WITHDRAWAL FROM SERVICE AND DISPOSAL	22
11.0	MONITORING PRE-CHARGE PRESSURE	23

1.0

INTRODUCTION

EN 14359 standard defines the device described in this manual as follows: A gas pressurized accumulator for hydraulic applications. Subsequently, the device is simply referred to as the 'accumulator'. The accumulator is designed, manufactured and tested according to the PED (2014/68/EU) guidelines.

When the instructions of this manual and the limit values for the accumulator are followed, the operation is safe and accumulator will remain functional throughout the planned lifecycle. The accumulator is safe and reliable to use when it is serviced according to the instructions specified in this manual. To avoid injuries and damage to the devices, it is important to read through these instructions before installation of the accumulator in a hydraulic system.

Hydroll Oy reserves the right to make changes to its products without prior notice. The information provided in this

instruction manual is valid at the time of its publication. The manufacturer will not be liable for direct or indirect injuries or material damages if the instructions provided below are not complied with.



2.0

GENERAL SAFETY INSTRUCTIONS

Read these safety instructions carefully before using this product!

Hydraulic accumulators are pressure vessels and must be treated accordingly. Only trained and qualified personnel should perform installation and maintenance procedures on the accumulators. Following safety instruction must always be followed.



DANGER
Failure to follow these instructions will result in death or serious injury!

Never use power tools to open the gas valve!

- Empty the accumulator of the nitrogen by using the charging kit.
- If the gas valve needs to be removed, do it with the impression that there are still pressure in the accumulator. There is a possibility that the gas valve and/or the charging kit have damaged and pressure measurement is incorrect.
- Use proper hand tool (for example 19 mm socket wrench for M16 x 2,0 mm) to open the gas valve.
- Make sure that there is no one on front of the gas side of the accumulator and work on the side of the accumulator.
- First open the gas valve 1 - 1,5 turns. If there is gas coming from the connection between the accumulator and the gas valve, wait until the accumulator is fully depressurized. After this, if you are confident that there is no pressure in the accumulator, you can screw the gas valve off.

Hazard of explosion

- Only use nitrogen (N₂) as a charging gas. Never use air or oxygen for charging (this may lead to an explosion). Never exceed the design pressure. Use a pressure reducer while charging.
- Never loosen the gas valve if the accumulator is pressurized.
- Check that hoses and connectors are in good condition before charging. They are subjected to high pressure under which the faulty parts may break and cause injury.
- Never open the accumulator.
- Never disassemble a pressurized accumulator. The energy of pressurized accumulators may discharge suddenly. Contact your dealer or manufacturer in case of failure and for maintenance procedures.
- The accumulator structure and operation may not be modified in any ways. Never do changes of any kind to accumulator design.
- Always consider accumulator contain pressure until proven otherwise.
- For preventing any accumulator damages ensure the cleanliness of the hydraulic system that will be connected to the accumulator.
- Damaged accumulator is not allowed in any circumstances to connect to the system.
- Always wear safety glasses, and chemical resistant protective gloves.

3.0

WARRANTY

Hydroll provides a one-year material guarantee on its accumulators provided that the instructions for installation and operation are followed and the acceptable accumulator limit values have not been exceeded. The guarantee does not cover normal wear during the use of the accumulator. Contact to Hydroll personnel in case of failure of the accumulator during the warranty period. Hydroll is not responsible of changes of any kind made to accumulator design.

3.1 Limitation of the liability

Only trained and qualified personnel should perform installation and maintenance on the accumulators. Manufacturer's installation and maintenance instructions must always be followed in combination with local working and safety procedures and guidelines.

Hydroll is not in responsible of direct or indirect damages that have been caused by accumulator misuse, mishandling or faulty installation by not following the manufacturer's instructions. Neither is the manufacturer responsible of the direct or indirect damages caused by neglecting of the local working and safety instruction.

4.0

TECHNICAL SPECIFICATIONS, LABELS AND STRUCTURE

These instructions apply to the accumulator sizes ID 50 to 250 mm, with a pressure area between 250 and 650 bars depending on the accumulator model and a capacity between 0.1 to 100 liters. Hydrroll piston accumulator product groups: HPS series includes single piston accumulators, HPD series includes dual port accumulators and HDC series includes dual chamber accumulators.

4.1 Technical specifications and labels

The accumulator label contains the following information:

- Hydrroll Oy contact details
- Serial and lot numbers
- Date of manufacture
- Type consisting of the accumulator series, the design pressure and the inner diameter values
- UN number and class
- Design pressure
- Temperature area
- Capacity
- Test pressure
- Date of pressure test
- Gas pre-charge pressure
- Device warnings
- Compliance markings (CE)
- Test oil cleanliness level

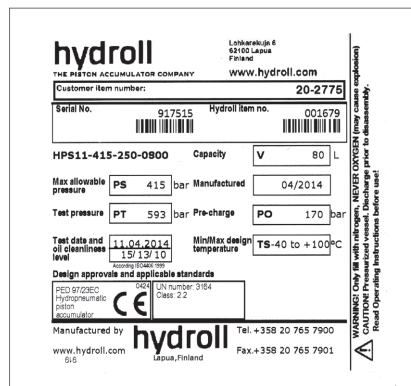

FIGURE 4.1 Examples of the product labels

4.2 General illustration of the accumulator structure

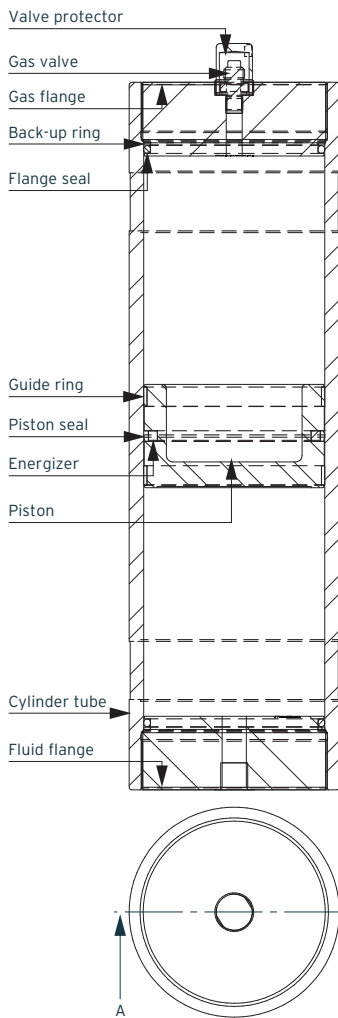

FIGURE 4.3 Section A-A, accumulator with standard gas valve type M16x2

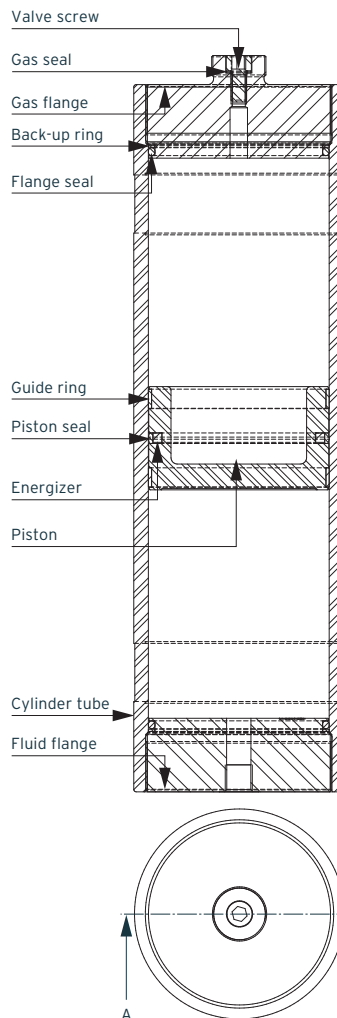
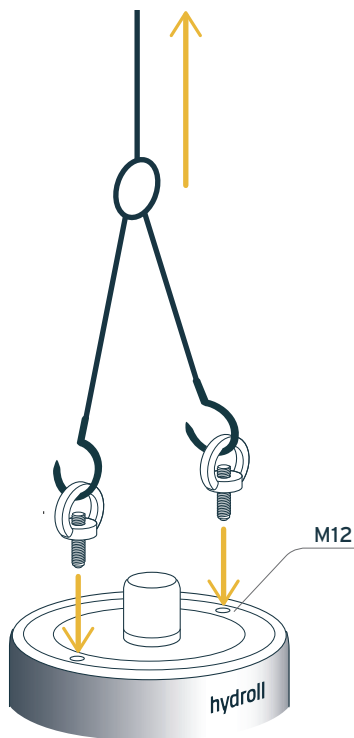

FIGURE 4.2 Section A-A, accumulator with gas valve type M28x2

5.0

INSTALLATION



Following list provides step-by-step procedure for the accumulator installation. **Note!** See the General Safety Instructions on page 5.

1. Visually inspect the accumulator for damage.
2. Handle the accumulator with care to avoid damaging the paintwork. Damage to the paintwork may expose the device to corrosion. Paint damages must be repaired immediately with 2-component polyurethane paint.
3. Check the capacity and the design pressure of the accumulator on its label. Ensure that the indicated temperature range is appropriate for the prevailing conditions. Never exceed the design pressure.
4. Ensure the cleanliness of the hydraulic system that will be connected to the accumulator. The accumulator manufacturer's guarantee will be void if the contaminants in the system enter the accumulator and damage it.
5. Hoisting points: In case accumulator has two threaded holes (M12) at each end of the accumulator to enable the mounting of lifting eyes or hoisting rings. See the figure 5.1.

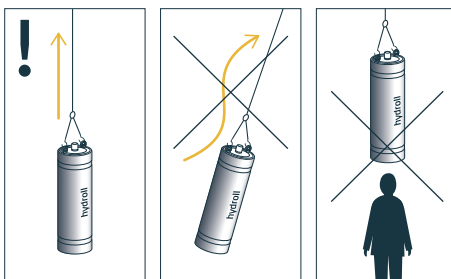

FIGURE 5.1 Hoisting points

5.0
INSTALLATION

6. Where possible, install the accumulator in an upright position with the gas side upwards. This will ensure the longest possible service life. Other positions are also allowed since the piston pressure accumulator construction will be functional regardless of the position. See figure 5.2.

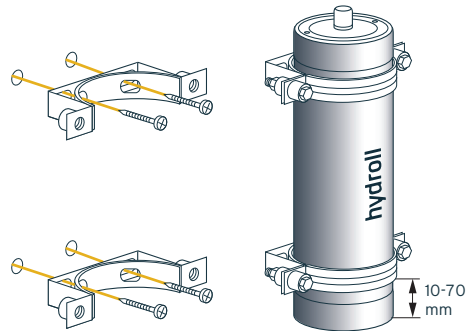

FIGURE 5.3 Recommended clamp positions

7. Attach the accumulator with the clamps provided by the manufacturer as illustrated in Figure 5.3.

8. Measure the pre-charge within one month after the installation.

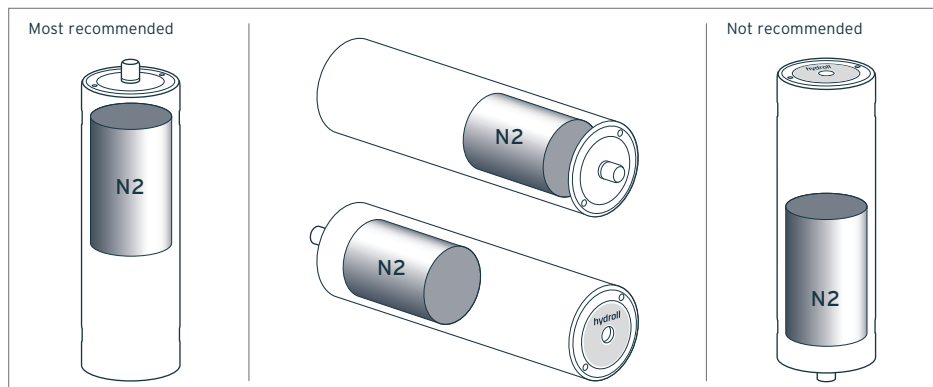

FIGURE 5.2 Mounting positions



IMPORTANT

Note: The torque of the binding bolt between the clamp and the accumulator. M10 thread \approx 20 Nm, M12 thread \approx 30 Nm.



DANGER

Damaged accumulator should not be connected to the system.

6.0

MAINTENANCE

General guidelines at maintenance:

- See the General Safety Instructions on page 5.
- If the operation of the accumulator is unsatisfactory, check the pressure and add gas where necessary. If the pressure is discharged from the accumulator after recharging, contact your dealer or manufacturer.
- Ensure the hydraulic system oil contains no contaminants and change the oil and filter according to the device manufacturer's instructions.
- Clean the accumulator's outer surfaces and ensure that the paintwork is intact when checking the pre-charge pressure. Cleaning helps prevent corrosion. Damages to the paintwork should be repaired immediately, since the accumulator structure does not allow for corrosion. Repair the paintwork with two-component polyurethane paint.
- Check the torque of the accumulator clamp bolts during the periodical maintenance.
- Only use the manufacturer's original spare parts. Contact the manufacturer when necessary.

6.1 Checking the pre-charge pressure

Check the pre-charge pressure at minimum once a year and write the result on the manual form attached in this document to monitor the accumulator's condition. Where necessary, add nitrogen gas (N₂) to the accumulator. Detailed instructions for N₂ filling see chapters HPCK charging kit for gas valve M16 and M28 charging kit for gas valve M28.



IMPORTANT

The maximum operating pressure, the extent and speed of pressure fluctuation, and the frequency of extreme operating temperatures will affect the gas pre-charge pressure inspection interval.

After inspection the pre-charge ensure the gas valve functionality by adding soap water in the top of the valve to detect potential leakages.

6.1.1 Important steps:

- If the operation of the accumulator is unsatisfactory, check the pressure and add gas where necessary. If the pressure is discharged from the accumulator after recharging, contact your dealer or manufacturer.
- Ensure the hydraulic system oil contains no contaminants and change the oil and filter according to the device manufacturer's instructions.
- Clean the accumulator's outer surfaces and ensure that the paintwork is intact when checking the pre-charge pressure. Cleaning helps prevent corrosion. Damages to the paintwork should be repaired immediately, since the accumulator structure does not allow for corrosion. Repair the paintwork with two-component polyurethane paint.
- Check the torque of the accumulator clamp bolts during the periodical maintenance.
- Only use the manufacturer's original spare parts. Contact the manufacturer when necessary.



WARNING

Please follow these instructions accurately in order to prevent risk situations and air access to accumulator. Always wear eye protection glasses and chemical resistant protective gloves.



DANGER

Use only dry nitrogen (N₂). Air or oxygen could cause an explosion. Use a pressure reducer while charging.



DANGER

Check that hoses and connectors are in good condition before charging. They are subjected to high pressure under which the faulty parts may break and cause injury.



DANGER:

Before any nitrogen pressurization measurement the accumulator of the hydraulic circuit under pressure has to be isolated and discharged on the hydraulic side. If required, immobilize it and define a safety zone.



ATTENTION

Check the preliminary filling pressure within one week of filling and thereafter at twelve-month intervals. By attending to leakages, damage to the accumulator and the system is prevented.



IMPORTANT

Please note that temperature will have an effect on the nitrogen pressure. The manufacturer will indicate the pre-charge pressure (P₀) at +20°C. The pressure change will comply with formula $P = P_0 * (T + 273) / 293$.

6.1.2 Temperature effect

Gas pressure changes in relation to temperature. Accumulator's pre charge (P₀) has been set on 20°C temperature (T₀). You will find P₀ pressure value on the accumulator label. Calculate right pre charge (P₁) if accumulator's actual temperature (T₁) differs from (T₀).

Formula:

$$P_1 = P_0 * T_1 / T_0$$

Where:

P₀ = preset pre-charge pressure [bar]

T₁ = current temperature of accumulator [K]

T₀ = temperature at preset of pre-charge
(273 + 20 = 293K)

For example:

P₀ = 125 bar, T₁ = 30°C, T₀ = 20°C

$$P_1 = 125 \text{ bar} * (273 + 30) / (273 + 20)$$

$$P_1 = 129,3 \text{ bar}$$

6.2 HPCK charging kit for gas valve M16

HPCK charging unit is suitable for gas valves with M16 x 2 mm thread used in Hydroll piston accumulators. In the HPCK charging unit the connector to nitrogen gas bottle is size: 24,32 x 1/14". **Note!** See the General Safety Instructions on page 5.

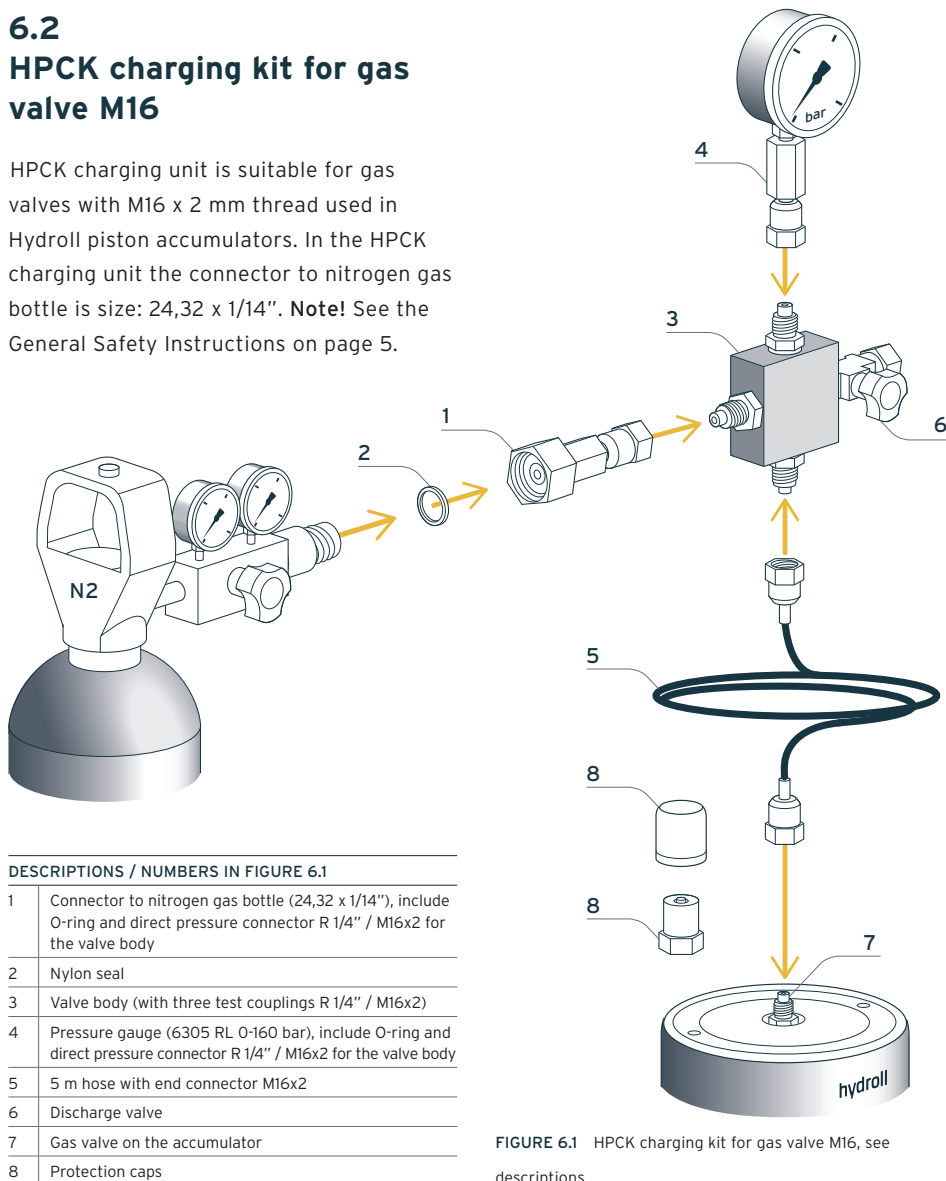

FIGURE 6.1 HPCK charging kit for gas valve M16, see descriptions

The standard type gas valve used in Hydroll piston accumulator is HGV1620, M16 x 2 with operation temperature range -25°C to +80°C. The optional type M16 x 2 arctic is used in arctic conditions with operation temperature from -45°C to +80°C.

1. Fix the gas bottle connector (1), pressure gauge (4) and hose (5) to the body.
2. Connect the charging unit to the nitrogen bottle with connector (1). Use the adjustable spanner. Remember the nylon seal (2).
3. Make sure that the discharge valve (6) is closed before proceeding.
4. Remove the gas valve protection caps (8) from the accumulator.
5. Gently connect charging units hose / end connector (5) to gas valve on the accumulator (7), hand tight only.
6. Check pre-charge pressure on the pressure gauge (4).
7. If needed, increase the pre-charge pressure by opening gas bottle valve gently. Charge gas pressure to wished value and close the gas bottle valve. Wait for a while (5 min) to get pressure settled. Charge more if needed.
8. If needed, decrease the pre-charge pressure by opening the discharge valve (6) on the valve body (3) gently. When gas pressure is at wished value, close the discharge valve (6). Wait for a while to get pressure settled. Discharge again if needed.
9. When pre-charge pressure has been set, gently disconnect (by hand) the hose end connector (5) from the gas valve on the accumulator (7).



WARNING

Make sure that you are not unscrewing the gas valve!

10. Check with soap water or other leak detector liquid gas valve (7) for leaks.
11. Connect both gas valve protection caps (8) back to the accumulator.
12. Disconnect the valve body (3) with the gas bottle connector (1) from the nitrogen bottle.

6.3 M28 charging kit for gas valve M28

M28 charging kit is used for gas valves with M28 x 1.5 mm thread used in Hydrill piston accumulators. The connector in M28 charging kit to nitrogen gas bottle is size: 24,32 x 1/4". **Note!** See the General Safety Instructions on page 5.

DESCRIPTIONS/ NUMBERS IN FIGURE 6.2

1	Connector to nitrogen gas bottle (24,32 x 1/4"), include O-ring and direct pressure connector R 1/4" / M16x2 for the valve body
2	Nylon seal
3	Hose with end connectors
4	Hand wheel (the square bolt)
5	Pressure gauge
6	Gas valve connector M28 x 1.5
7	Discharge valve
8	Gas valve on the accumulator
9	Protection cap

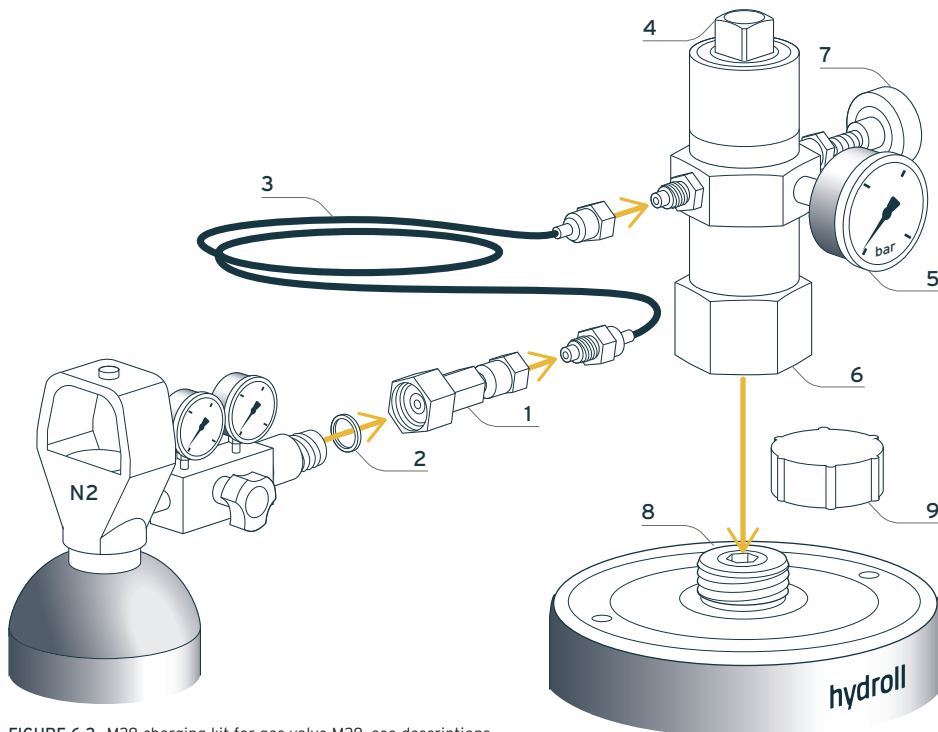

FIGURE 6.2 M28 charging kit for gas valve M28, see descriptions

The product name for gas valve used in Hydroll piston accumulator is M28 x 1.5 gas valve with temperature range from -45°C to +80°C.

Pre-charge operation for accumulator:

1. Fix the gas bottle connector (1), pressure gauge (4) to the body.
2. Connect the charging unit to the nitrogen bottle with connector (1). Use the adjusting key. Remember the nylon seal (2).
3. Make sure that the discharge valve (7) is closed before proceeding.
4. Remove the gas valve protection cap (9) from the accumulator.
5. Gently connect gas valve connector M28 x 1.5 (6) to gas valve on the accumulator (8), hand tight only.
6. Unscrew the square bolt (4), and check the pressure on the pressure gauge (5); if the pressure is too high open slightly the discharge valve (7).
7. Fasten the square bolt (4), with torque 15 - 20 Nm, and discharge the residual pressure from the body of the device with the discharge valve (7).
8. When pre-charge pressure has been set, gently disconnect (by hand) the connector (6) from the gas valve on the accumulator (8).
9. Check with soap water or other leak detector liquid gas valve (8) for leaks.
10. Connect gas valve protection cap (9) back to the accumulator.
11. Disconnect the valve body with the gas bottle connector (1) from the nitrogen bottle.



WARNING

Make sure that you are not unscrewing the gas valve!

7.0

CALCULATED LIFE TIME - DYNAMIC LOAD

Theoretical accumulator fatigue based on EN 13345-3 standard. The graph below illustrates the worst-case scenario for structure fatigue.



NOTE
Practical fatigue curve is application dependent however pressure variation being the main factors that influence on the shape and location of the curve.

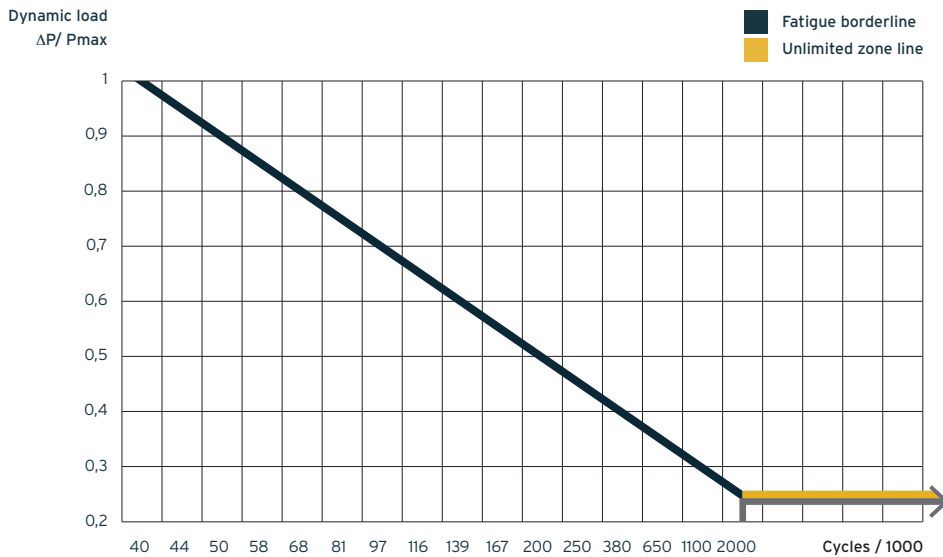

FIGURE 7.1 The worst-case scenario for structure fatigue

8.0

STORAGE AND TRANSPORTATION

8.1 Storage

The accumulator should be stored in a dry and cool spot with a constant temperature. All accumulator joints should be plugged. The accumulator should not be exposed to excessive heat (i.e. temperatures over 40°C for long periods of time).

Handle the accumulator with care. Use approved lifting devices to lift and move the accumulator. Hoisting points of accumulator, see the chapter 6 Installation.

If the accumulator is over 180 mm and storage time over six months, it is recommended to storage accumulators in a vertical position gas side down. This way residues of oil will keep the piston sealing lubricated. Oil helps piston seal to keep its elasticity and original material benefits.



IMPORTANT

Take particular care not to damage the charging valve.

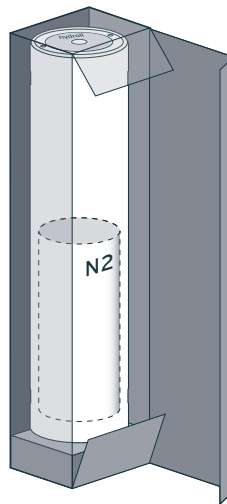

FIGURE 8.1 If the accumulator is over 180 mm and storage time over six months, it is recommended to storage accumulators in a vertical position gas side down.



IMPORTANT

If the accumulator is stored for more than six months, the pre-charge pressure should be checked taking the ambient temperature correction into account.

8.2 Transportation

Pressurized Hydro pneumatic Piston Accumulators are considered as dangerous goods UN 3164, Articles, Pressurized, Pneumatic, 2.2 when the accumulator is pre-charged with compressed nitrogen on Road, Railway, Sea and Air. For this reason the shipping company should have qualified personnel to handle the shipments and packaging of accumulators. EU legislation requires that at least one person has been educated for shipping dangerous goods in the company (ADR / RID-, IMDG- and IATA-regulations).

Unpressurised accumulator is not considered as dangerous goods UN 3164 and may also be transported as standard airfreight.

Valid documentation and instruction for transportation and packaging are downloadable in Hydroll www-site:

www.hydroll.com

Navigate: Downloads > Technical Documentation > Transportation Documentation



IMPORTANT

Take particular care not to damage the charging valve.

9.0

PRACTICAL ADVICES FOR USER

Soapy water may be used to locate gas leakages. Its use is also recommended to ensure valve performance after pressure checks.

Pre-charge pressure may be checked with the aid of the liquid side pressure measurement: the system is pressurized to exceed the accumulator's pre-charge pressure, and the system pressure is discharged by limiting the outflow in order for the pressure to decrease slowly (~5 bars/min). Once the system pressure has reached the accumulator's pre-charge pressure, the system pressure decreases rapidly.

Recommendation for system equipment:

- Pressure relief valve, the opening pressure should be lower than accumulator maximum operating pressure
- Stopcock to allow the isolation of the charger from the system

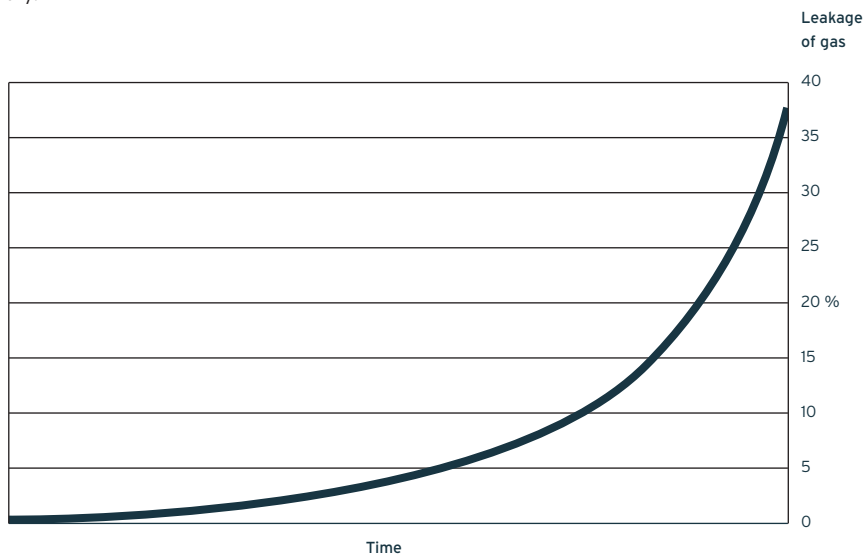

FIGURE 9.1 Normal wear and the resulting leakage in relation to time

10.0

WITHDRAWAL FROM SERVICE AND DISPOSAL

Note! See the General Safety Instructions on page 5.

1. A pressurized accumulator must not be discarded; the pressure should be discharged before disposal.
2. Using a Hydroll charging device or a connector compatible with the valve can discharge the pressure.
3. Once the pressure has been discharged and the gas valve has been removed, the accumulator may be handed over to metal recycling.

Hydroll Oy

PL 12, LOHKAREKUJA 6
FIN-62101 LAPUA, FINLAND
TEL +358 (0)20 765 7900
FAX +358 (0)20 765 7901

INFO@HYDROLL.COM
WWW.HYDROLL.COM

hydroll

THE PISTON ACCUMULATOR COMPANY